

MODEL 901-1 SPRAY ASSEMBLY



Pneumatic ducts present a very difficult environment for fire protection devices. The high density of material in the air stream can clog a sprinkler nozzle and causes significant wear. Larger objects carried by the air stream can also destroy typical sprinkler heads. The nozzle of the 901-1 Spray Assembly is made of stainless steel and closes tight when not in use. It has a very smooth, low profile, wear resistant design.



The air stream in the pneumatic duct can be traveling at a very high speed and could carry sparks or embers at this rate. The 901-1 must be installed on the duct a minimum distance downstream from the detectors. This distance is based on the air speed.

WWW.**HANSENTEK**.com



4141 Sladeview Crescent, Unit 18, Mississauga, Ontario, Canada L5L 5T1
Phone: 905-607-5780 Email: info@hansentek.com

A strainer is included as part of the assembly in order to keep debris out of the solenoid valve. An optional ball valve and supervisory switch is recommended to help with maintenance and facilitate cleaning of the strainer.



The nozzle can be easily mounted from the outside of the duct through a blind hole. A unique flange is fixed in place with the use of a split washer and nut assembly.

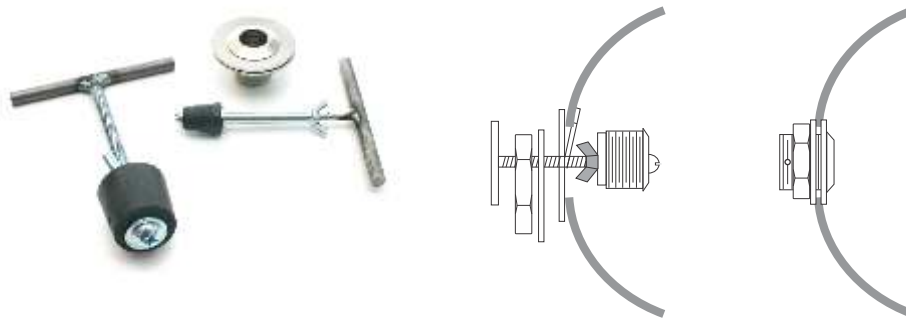

A hole saw and installation tool are provided with each order.

